



Rapid Defender

Temporary VSB



Product Benefits

- A physical and visual security deterrent
- Quick and easy to deploy, remove and relocate - minimising disruption
- Lightweight design allows easy transportation and installation
- Suitable for all types of sites - accommodating road cambers and uneven surfaces
- No special tools or lifting equipment required
- Over 65% lighter than concrete solutions
- Manufactured from 100% recycled rubber
- Innovative modular design enabling integration with other HVM solutions
- Optional covers for branding opportunities



Specifically designed to provide protection for crowds of people at events from vehicle as a weapon (VAAW) attacks, the Rapid Defender is a temporary vehicle security barrier (VSB). Requiring no foundations, this surface mounted system can be quickly deployed almost anywhere, from the streets surrounding stadiums to uneven festival sites, in a matter of minutes.

Made up of individual robust rubber units weighing just 49kg each, connected by steel cables or rods, the modular system can be set up quickly and easily, removed and used again and again. With no special tools or lifting equipment required, four men can manually install a barrier across the width of a road in less than five minutes.

The innovative design of the Rapid Defender allows it to be anchored or integrated with other temporary or permanent hostile vehicle mitigation (HVM) systems to create a stronger physical barrier as part of a holistic HVM solution.





Technical Information

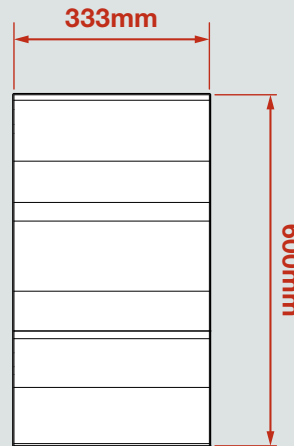
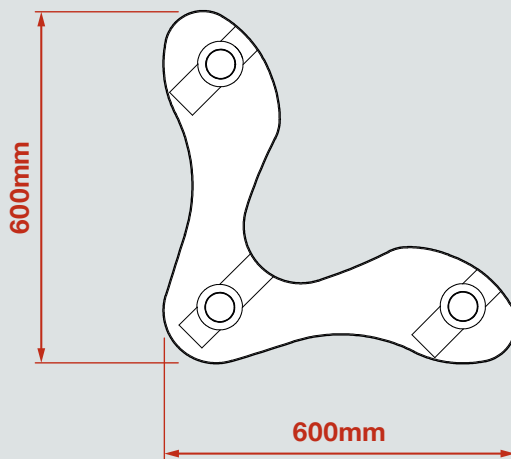

Manufactured from 100% recycled rubber and polyurethane, the Rapid Defender is supplied complete with steel securing cables and fixings.

Size	333 x 600 x 600 mm
Weight	49kg
Connectivity	20mm Ø steel cables or rods

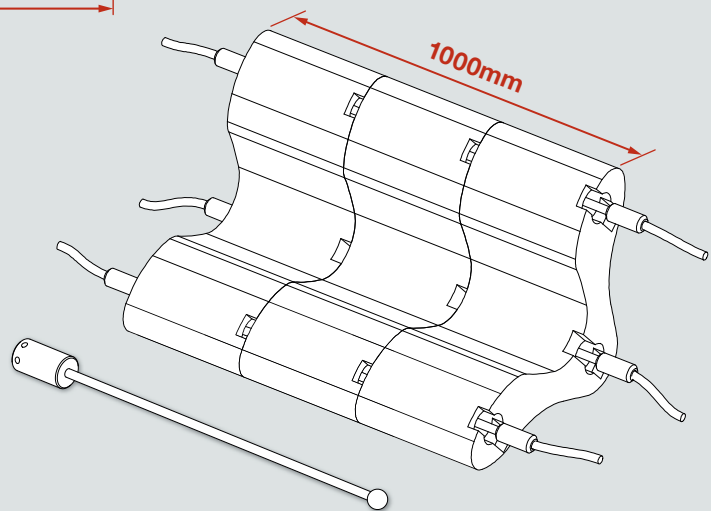

For more information, please call the Rosehill Security sales team on **+44 (0)1422 839 456**, or email info@rosehillsecurity.com

